

### FEATURES

- Frequency range 8MHz to 60MHz, fundamental mode
- Ultra-small package 3.2mm x 2.5mm x 0.6mm
- Entire package may be grounded via metal lid and two pads
- Packaged in standard EIA tape and reel
- Extremely low ageing with high shock and vibration resistance
- Ideal for PDAs, hand-held GPS, PCMCIA etc.

### DESCRIPTION

MT crystals are ultra-miniature AT-cut crystals covering the frequency range 8MHz to 60MHz in fundamental mode, 40MHz to 125MHz. Their small size and low mass makes these crystals ideal for miniaturized hand-held equipment and similar high-density applications.

### SPECIFICATION

Frequency Range:	8.0MHz to 125.00MHz
Operating Mode:	AT-Cut Fund./AT-Cut 3rd OT.
Calibration Tolerance at 25°C*:	from ±5ppm (±10, ±20 or ±30ppm standard)
Frequency stability*	
-10° to +60°C	from ±5ppm
-20° to +70°C	from ±10ppm
-40° to +85°C	from ±15ppm
Storage Temperature:	-50°~+105°C
Equivalent Series Resistance:	See table
Shunt Capacitance (C0):	2pF to 4pF typical, 5pF maximum
Load Capacitance (CL):	Series or from 8pF to 32pF (Customer specified CL)
Ageing:	<±3ppm per year at +25°C
Drive level:	10µW typical, 100µW maximum
Reflow Soldering:	10s maximum at 260°C twice or 180s at 230°C, once.
Packaging:	12mm EIA tape and reel

\*Note: Tighter stability, tolerance and lower ESR values are available.

### EQUIVALENT SERIES RESISTANCE

Frequency Range MHz	ESR Ω Max.	
8.0~9.999	600	
10.0~11.999	200	
12.0~29.999	100	
30.0~54.000	60	
40.0~125.00	80	AT-Cut 3rd Overtone

### STANDARD PART NUMBERS AND SPECIFICATIONS

Frequency (MHz)	CL (pF)	Euroquartz Part Number	Tolerance (±ppm)/ Stability (±ppm)/ Temp. Range (°C)/ Max. ESR (Ohms)
16.0000	12	X32-16000-12	30/50/-20+70/100R
16.3840	12	X32-16384-12	30/50/-20+70/100R
20.0000	12	X32-20000-12	30/50/-20+70/100R
20.5720	12	X32-20572-12	30/50/-20+70/60R
20.9450	12	X32-20945-12	30/50/-20+70/60R
24.5500	12	X32-24550-12	30/50/-20+70/60R
24.5760	12	X32-24576-12	30/50/-20+70/60R
29.4912	12	X32-29491-12	30/50/-20+70/60R
32.0000	12	X32-32000-12	30/50/-20+70/60R
32.7680	12	X32-32768-12	30/50/-20+70/60R
40.0000	12	X32-40000-12	30/50/-20+70/60R
48.0000	12	X32-48000-12	30/50/-20+70/60R
50.0000	12	X32-50000-12	30/50/-20+70/60R



### OUTLINE & DIMENSIONS

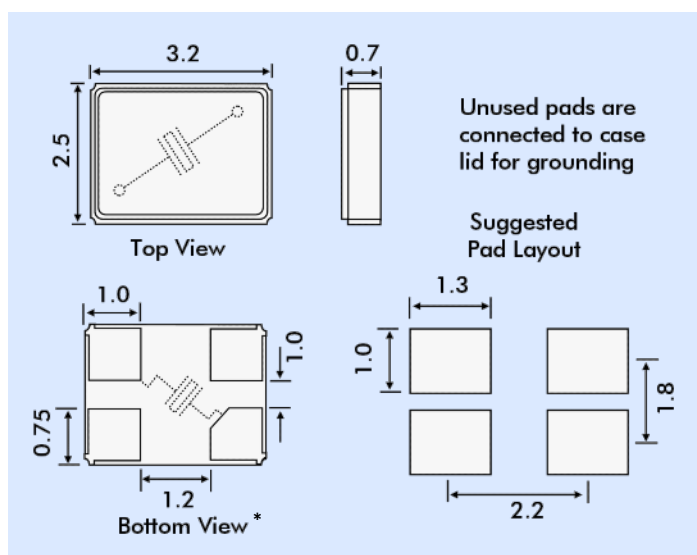

\* Note: These parts may be supplied with the chamfered pad in different positions. However, the crystal connection is always as shown above.

### PART NUMBER GENERATION

Part numbers for X32 crystals are generated as follows:

